

WILGARD® LT SERIES GUARD RAIL

Wilgard® LT Guard Rail provides high value at a competitive price and is ideal for lighter-duty guarding of personnel areas, work stations and walkways. Wilgard Guard Rail systems can be ordered in single, double or triple rail designs. Choose between bolted (standard) or lift-out rail types. All guard rail components include necessary hardware and anchors.

Highlights

- Reduces downtime for equipment and manpower
- Prevents workers' compensation claims
- Directs pedestrian traffic flow
- Lift-out rail options available



48-Hour quickship available for standard sizes!



HOW IT WORKS

Wilgard® LT ships to your location with all necessary hardware required for installation. The guard rail base plates are anchored to your concrete floor using (4) 3/8" x 4" wedge bolts. Once installed, Wilgard LT provides a highly visible yellow barrier, designating traffic patterns for forklifts and personnel. Wildeck specialists will work with you to identify appropriate rail lengths and height needed for your application. Lift-out rail options exist for equipment and machinery that require access by personnel. Special fabrication options include: custom rail lengths and base plate - column offsets.



WILGARD® LT SERIES GUARD RAIL

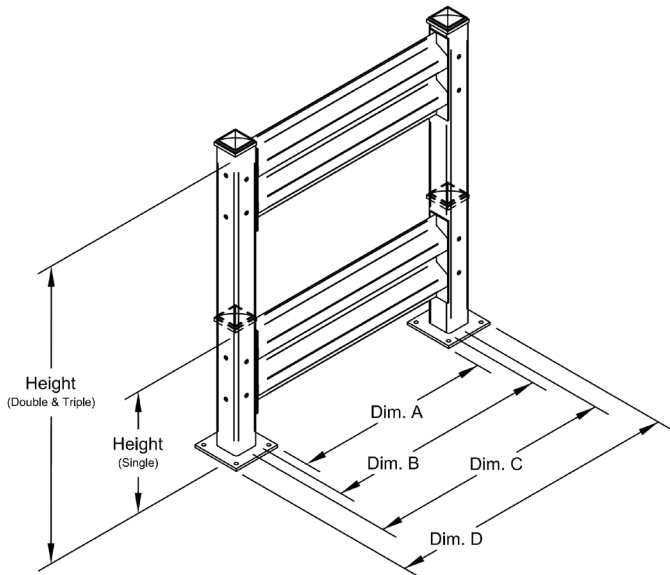

SPECIFICATIONS

- Columns: 3-1/2" x 3-1/2" x 3/16" structural tube; 18" H single rail; 44" H double rail; 44" H triple rail
- Base Plates: 7" x 7" x 3/8" plate steel
- Anchors: 3/8" x 4" wedge bolts (included)
- Post Cap: Zinc plated snap-on steel cap
- Rails: Corrugated 14 gauge steel guard rails, 12" H with hemmed / rolled edges
- Lengths: 2 ft. – 10 ft. in one foot increments; lift-out rail adds 2-3/4" per section (reference Dim. C)
- Rail Hardware Pack: (4) 1/2" x 5" thru bolts, nuts, and flat washers
- Column Hardware Pack: (4) 3/8" x 4" wedge bolts, yellow plastic plugs for unused holes, and zinc plated snap-on cap
- Common column post used for lift-out or bolted rail systems (lift-out triple rail not available)

Component	Part #	Height	Weight (with hardware)
Single Rail Column	WCL18	18"	18 lbs.
Double Rail Column	WCL44	44"	36 lbs.
Triple Rail Column	WCLT44	44"	36 lbs.

Component	Part #	Dim. A (between baseplates)	Dim. B (rail lengths)	Dim. C (center to center)	Dim. D (out to out)	Weight (with hardware)
10' Guard Rail	WL10	113"	116 1/2"	120"	123 1/2"	50 lbs.
9' Guard Rail	WL9	101"	104 1/2"	108"	111 1/2"	45 lbs.
8' Guard Rail	WL8	89"	92 1/2"	96"	99 1/2"	41 lbs.
7' Guard Rail	WL7	77"	80 1/2"	84"	87 1/2"	37 lbs.
6' Guard Rail	WL6	65"	68 1/2"	72"	75 1/2"	32 lbs.
5' Guard Rail	WL5	43"	56 1/2"	60"	63 1/2"	28 lbs.
4' Guard Rail	WL4	41"	44 1/2"	48"	51 1/2"	23 lbs.
3' Guard Rail	WL3	29"	32 1/2"	36"	39 1/2"	19 lbs.
2' Guard Rail	WL2	17"	20 1/2"	24"	27 1/2"	15 lbs.
10' Lift-Out Guard Rail	WL10L	115 3/4"	116 1/2"	122 3/4"	129 3/4"	62 lbs.
8' Lift-Out Guard Rail	WL8L	91 3/4"	92 1/2"	98 3/4"	105 3/4"	53 lbs.
6' Lift-Out Guard Rail	WL6L	67 3/4"	68 1/2"	74 3/4"	81 3/4"	44 lbs.
4' Lift-Out Guard Rail	WL4L	43 3/4"	44 1/2"	50 3/4"	57 3/4"	35 lbs.

405 Commerce Street
Waukesha, WI 53186
262-549-4000 | 800-325-6939
www.wildeck.com

1040 So. Camino Oro
Goodyear, AZ 85338
800-360-6789

© Wildeck, Inc. 2019
Printed in USA • WGLT 1901



GUARDS
MEZZANINES
LIFTS
ACCESS